

**PROPRIETARY AND CONFIDENTIAL**  
 THE INFORMATION CONTAINED IN THIS DRAWING IS THE SOLE PROPERTY OF <INSERT COMPANY NAME HERE>. ANY REPRODUCTION IN PART OR AS A WHOLE WITHOUT THE WRITTEN PERMISSION OF <INSERT COMPANY NAME HERE> IS PROHIBITED.

		UNLESS OTHERWISE SPECIFIED:	NAME	DATE		
		DIMENSIONS ARE IN INCHES	DRAWN	SJB	03/20/17	TITLE: <b>60222-P Pole Mount</b>
		TOLERANCES:	CHECKED			
		FRACTIONAL ±	ENG APPR.			
		ANGULAR: MACH ± BEND ±	MFG APPR.			
		TWO PLACE DECIMAL ±	Q.A.			SIZE DWG. NO. REV <b>A 60222-P</b>
		THREE PLACE DECIMAL ±	COMMENTS:			
		INTERPRET GEOMETRIC TOLERANCING PER:				SCALE: 1:12
		MATERIAL				WEIGHT:
NEXT ASSY	USED ON	FINISH				SHEET 1 OF 2
APPLICATION		DO NOT SCALE DRAWING				

5

4

3

2

1

Drawing: #60222P  
60222-P Assembly Drawing

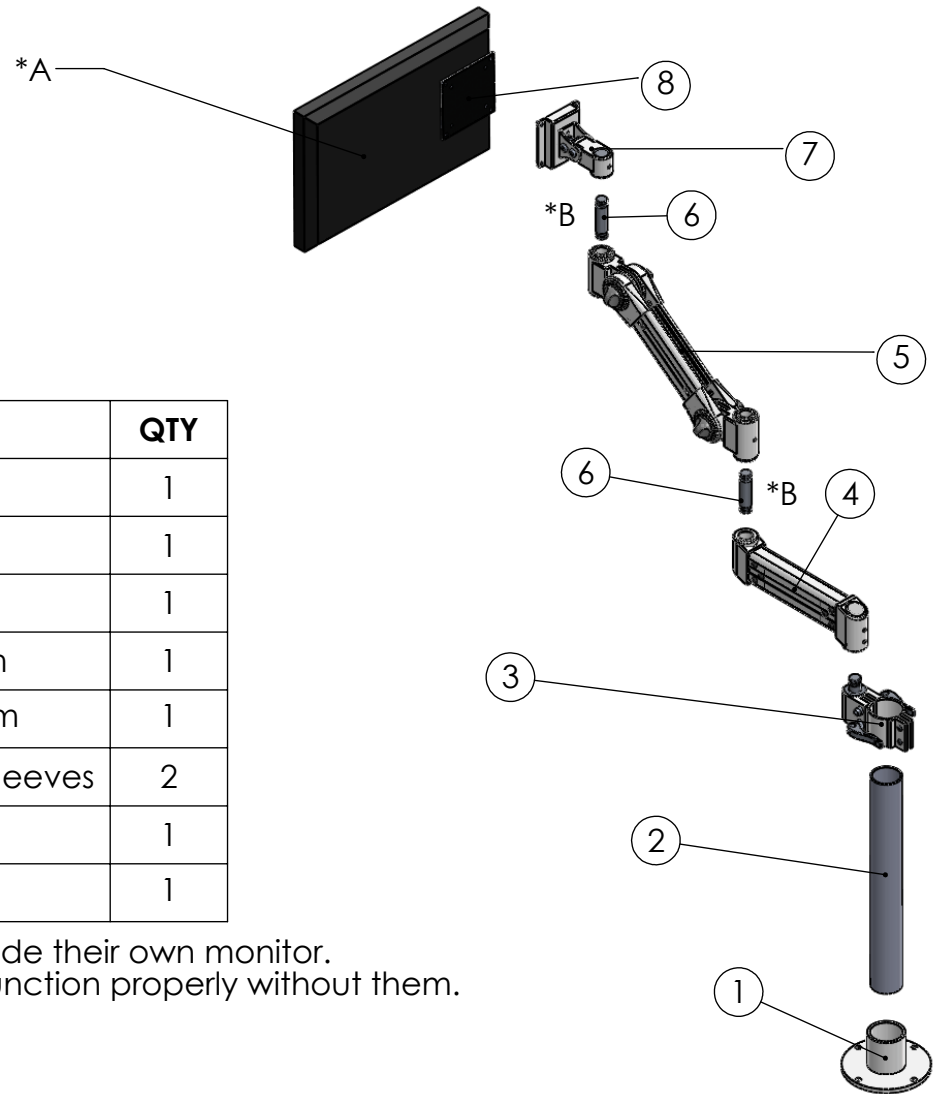

ITEM	#60222 PARTS	DESCRIPTION	QTY
1	25-33	Pole Base	1
2	23-22	16" Pole	1
3	25-40Q	Pole Bracket	1
4	22-03-3	10" Extension Arm	1
5	22-04-3	15" Adjustable Arm	1
6	Pivot Pins	Pivot Pins with Plastic Sleeves	2
7	21-01-B	Pivot Bracket	1
8	21-02-B	Adaptor Plate	1

\*A: Monitor NOT included in the assembly. Customer will provide their own monitor.

\*B: Do NOT remove plastic inserts from the arm, arm will not function properly without them.

**PROPRIETARY AND CONFIDENTIAL**  
THE INFORMATION CONTAINED IN THIS DRAWING IS THE SOLE PROPERTY OF <INSERT COMPANY NAME HERE>. ANY REPRODUCTION IN PART OR AS A WHOLE WITHOUT THE WRITTEN PERMISSION OF <INSERT COMPANY NAME HERE> IS PROHIBITED.

		UNLESS OTHERWISE SPECIFIED:	NAME	DATE
		DIMENSIONS ARE IN INCHES	DRAWN	SJB
		TOLERANCES:	CHECKED	03/20/17
		FRACTIONAL ±	ENG APPR.	
		ANGULAR: MACH ± BEND ±	MFG APPR.	
		TWO PLACE DECIMAL ±	Q.A.	
		THREE PLACE DECIMAL ±	COMMENTS:	
		INTERPRET GEOMETRIC TOLERANCING PER:		
		MATERIAL		
NEXT ASSY	USED ON	FINISH		
APPLICATION		DO NOT SCALE DRAWING		

TITLE: 60222P Assembly Drawing

SIZE	DWG. NO.	REV
<b>A</b>	60222-P	

SCALE: 1:12 WEIGHT: SHEET 2 OF 2